

**Update**

**giellesse**





Day and night  
collection.

Giellesse update

**A catalogue dedicated to the  
novelties of the collection.  
New typologies, accurate  
new introductions, new  
materials and finishes: these  
are the protagonists of the  
new Giellesse proposal.**

Frame day system, Downtown  
sofa, Tudor and Jerry coffee table,  
Frame sideboard.

Giellesse update

**Day Collection, an harmonious  
balance between exclusive elements  
to furnish the home surroundings.**



Tudor coffee table,  
Downtown sofa.

Giellesse update



Downtown sofa  
*metal champagne base  
and fabric covering.*

Giellesse update



Downtown armchair  
*metal champagne base*  
*and fabric covering.*

Giellesse update





Flexus Cristal day system

*metal rame structure,  
transparent glass and  
coal oak drawers.*

Giellesse update



Flexus Cristal day system

*metal rame structure,  
transparent glass and  
coal oak drawers.*

Giellesse update



Select sideboard system  
*glossy lacquered grigio ice,  
metal bronzo lacquered upper  
tray and side.*

Giellesse update



Frame day system

*thermo-treated oak with Calacatta gold marble, suspended bench with thermo-treated oak back panels, glossy lacquered grigio icesuspended element with champagne frame and bronzed glass doors.*

Giellesse update

**New aesthetics and new solutions for the modular day system that is now a classic of the Giellesse collection.**



Frame day system

*honey oak and matt lacquered  
antracite base and panels, matt  
lacquered antracite suspended  
element with metal vulcano  
frame and smoked glass.*

Giellesse update



Flexus day system, Downtown  
sofa, Tudor and Jerry coffee table,  
Jam mirror, Frame sideboard.

Giellesse update



Susan chair

*honey oak base, velvet  
and leather seat.*

Giellesse update



Frame day system, Pantheon  
table, Susan chair, Downtown sofa.

Giellesse update

**Unlimited idea of space requisites  
living, organizing, separating,  
containing, storing, decorating.**





Pantheon table

*honey oak base, Calacatta  
marble gold and metal  
champagne ring base.*



Giellesse update



Select day system, Susan chair, Pantheon table.

Giellesse update



Select sideboard system

*matt lacquered roccia,  
metal vulcano lacquered upper  
tray and side.*

Giellesse update



Flexus Cristal day system

*lacquered metal rame with led lights,  
matt lacquered bordeaux drawers.*

Giellesse update



Downtown bed, Club armchair,  
Frame chest of drawers.

Giellesse update

**Between technology and  
suggestiveness, new stylistic  
values for environments  
dedicated to personal space.**



Opera bedside table,  
Downtown bed.

Giellesse update



Opera tallboy  
*honey oak structure,  
Calacatta gold marble top.*

Giellesse update



Cover wardrobe,  
Downtown bed.

Giellesse update

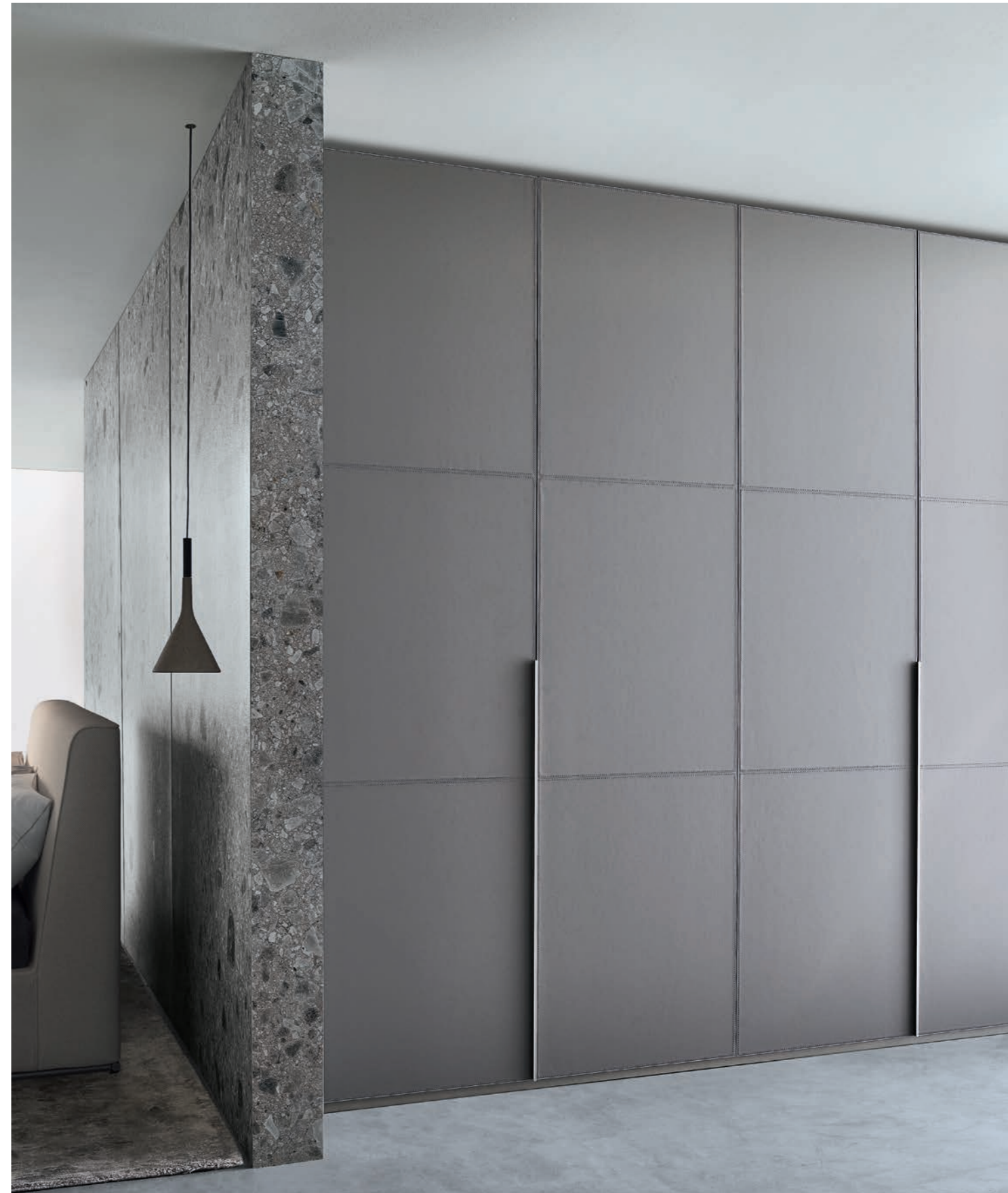







Kita wardrobe, Horizon portal,  
Levante bed, Opera bedside table,  
Frame chest of drawers, Susan chair.

Giellesse update

**Perfect architectural integration,  
contemporary image, sophisticated design  
that meet maximum functionality.**



Groove Plus wardrobe,  
Levante bed,

Giellesse update



Long Island chest of drawing,  
Soft Square pouf.

Giellesse update



Long Island chest of drawing

*thermo-treated oak,  
tortora leather top.*

Giellesse update



Sheer wardrobe

*stopsol smoked glass door with  
metal vulcano frame, internal  
silvertex melamine, matt lacquered  
grigio cloud drawers.*

Giellesse update



Cabin walk-in closet,  
Soft circle pouf.

Giellesse update

**The walk-in closet defined by rigorous  
aesthetic and compositional versatility.**





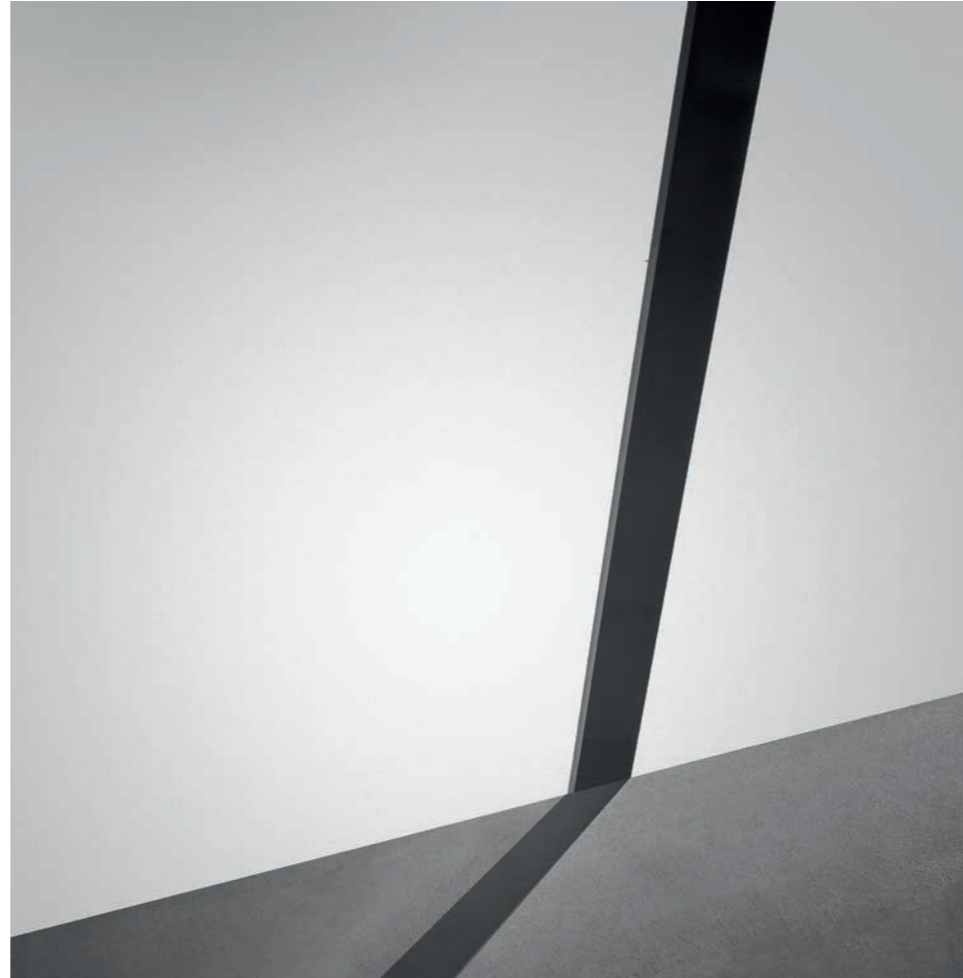

The new doors  
collection.

Giellese update

**Contemporary doors  
collection with a different  
approach designed for  
maximum flexibility and  
aesthetic, functional,  
technological and design  
customization.**

Kita wardrobe

*metal champagne frame  
and transparent glass,  
internal silvertex melamine.*

Giellesse update

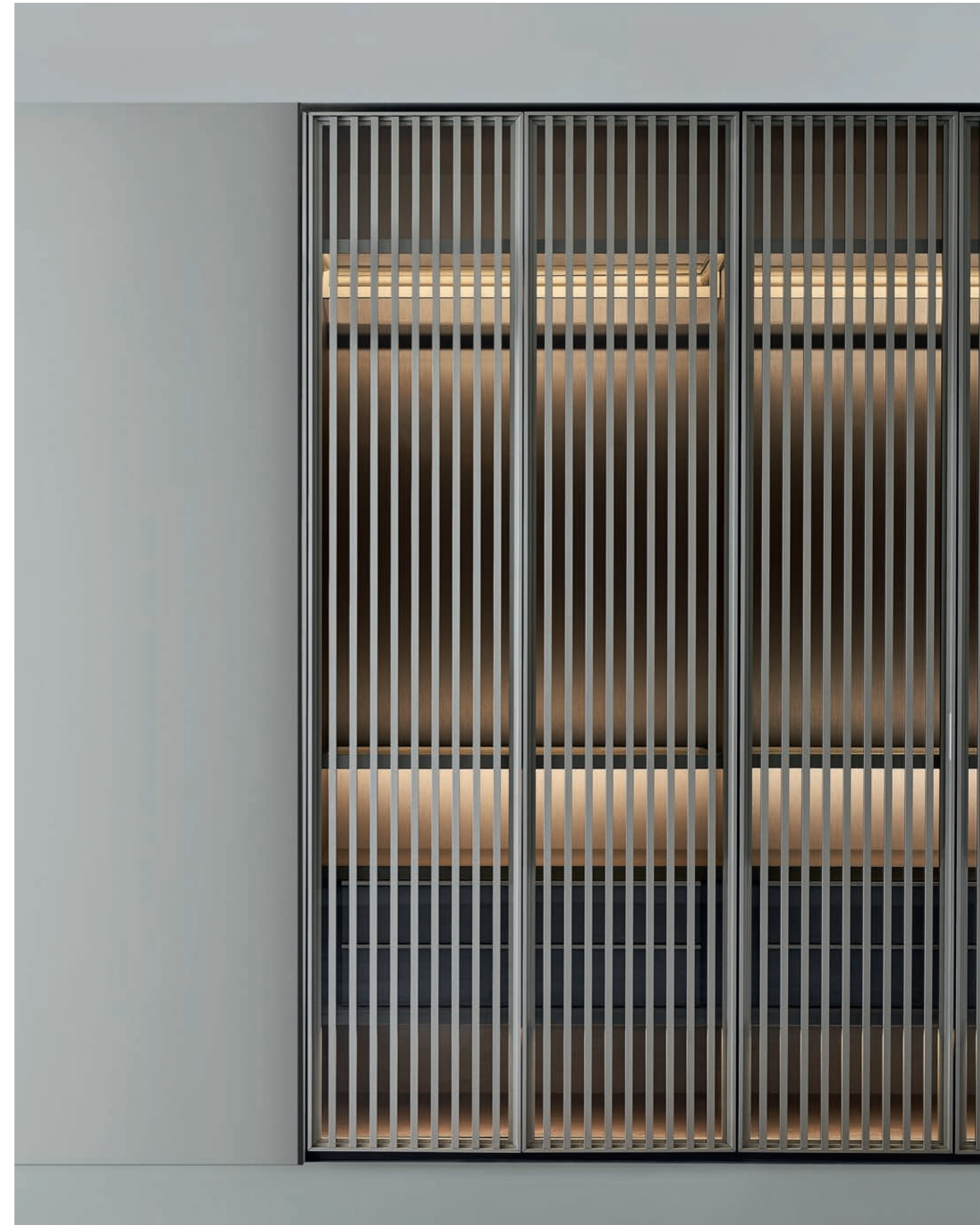

Groove Plus wardrobe

*thermo-treated oak, metal  
gold frame and integrated handle.*

Giellesse update



Horizon portal

*honey oak, glossy lacquered grigio  
cloud, full led lights back panel.*

Giellesse update



Portrait wardrobe

*glossy lacquered grigio cloud, metal  
champagne integrated handles,  
internal magnolia melamine.*

Giellesse update



Sheer wardrobe

*stopsol smoked glass door with  
metal vulcano frame, internal  
silvertex melamine, matt lacquered  
grigio cloud drawers.*

Giellesse update



Mayfair wardrobe  
*metal champagne frame  
and bronzed glass, internal  
magnolia melamine.*

Giellesse update





Cover wardrobe

*cenere leather doors, metal  
champagne profiles with  
integrated handles.*

Giellesse update



Flexus Cristal day system

*lacquered metal rame with led lights,  
matt lacquered bordeaux drawers.*

Giellesse update



**Sophisticated finishes, trendy colors, perfection of accessories. Each element of the composition contributes to define a homogeneous, refined, elegant system.**

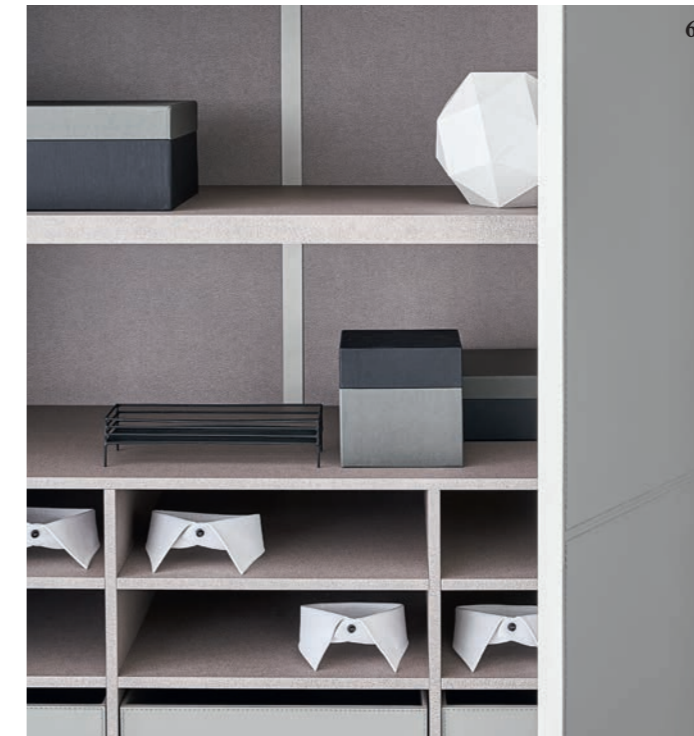
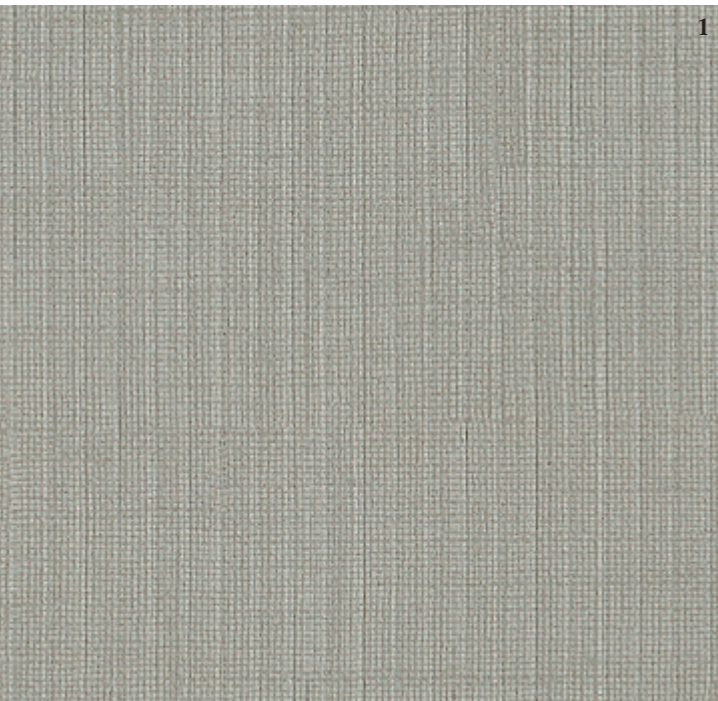

- 1 Melaminico Way. Way melamine.
- 2 Vassoio porta pantaloni estraibile in melaminico Way e dettagli cuoio. Extractible trousers tray in Way melamine and leather details.
- 3 Melaminico Zenit. Zenit melamine.
- 4 Interno armadio Portrait in melaminico Zenit attrezzato con ripiani inclinati portascarpe. Portrait wardrobe internal structure in Zenit melamine and sloping shelves for shoes.
- 5 Accessori interni cassetiera Long Island in rovere termocotto con top rivestito in cuoio tortora. Inner accessories of Long Island chest of drawers in thermo-treated oak with tortora leather top.
- 6 Interno armadio in melaminico Way attrezzato con ripiani, vani a giorno e cassetti cuoio. Way melamine wardrobe with shelves, open units and leather drawers.

LACCATO OPACO . MAT LACQUER

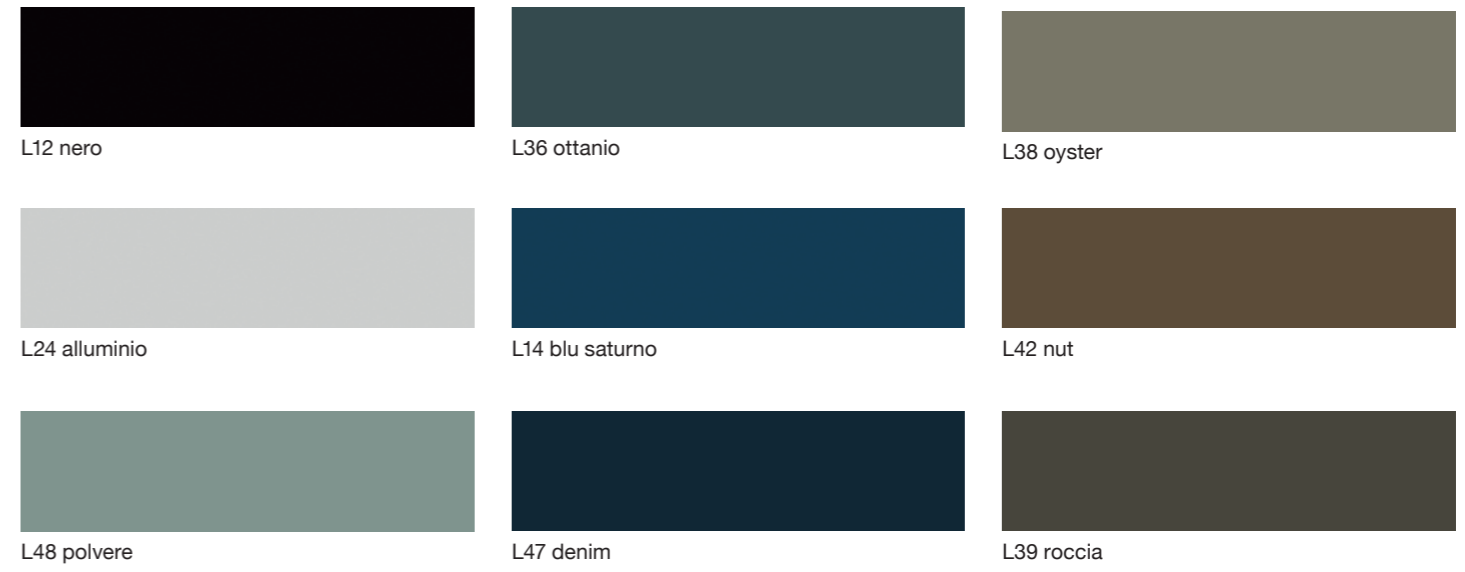

VETRO LACCATO OPACO . MAT LACQUER GLASS

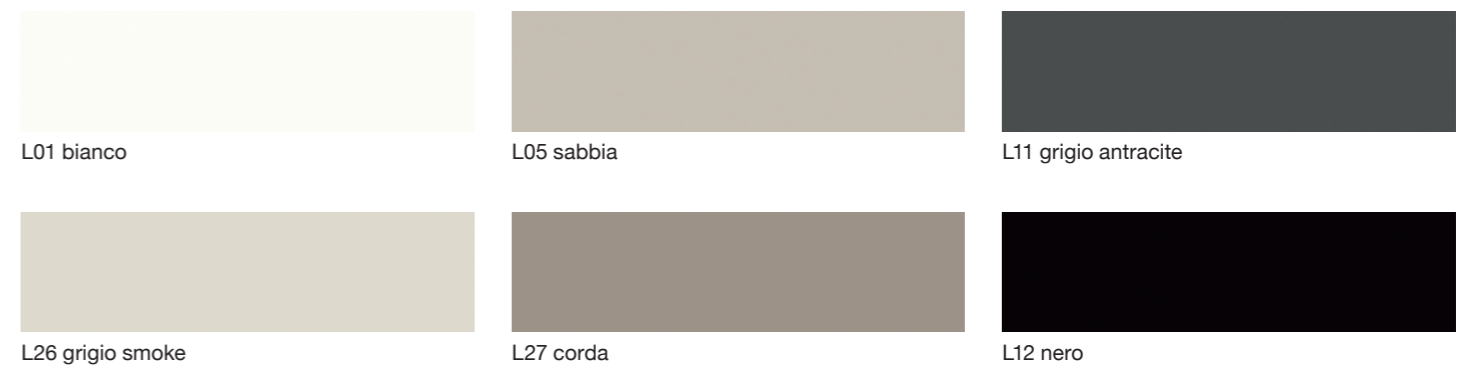

I campioni di colori e materiali hanno valore indicativo. The colour and material samples have an indicative value.

LACCATO LUCIDO . GLOSSY LACQUER

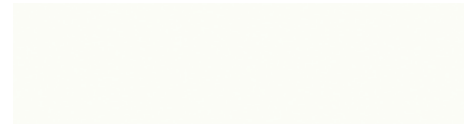

LU01 bianco



LU34 grigio ice



LU46 polvere



LU05 sabbia



LU08 cioccolato



LU38 oyster



LU35 tortora



LU12 nero



LU45 rosso falun



LU11 grigio antracite



LU36 ottanio

VETRO LACCATO LUCIDO . GLOSSY LACQUER GLASS

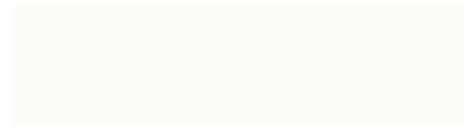

L01 bianco



L05 sabbia



L11 grigio antracite



L26 grigio smoke



L27 corda



L12 nero

MARMI OPACHI E LUCIDI . MATT AND GLOSSY MARBLES

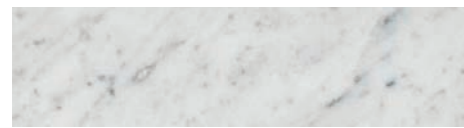

carrara

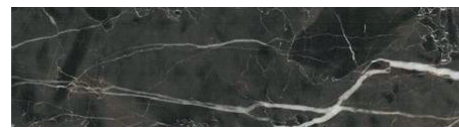

stardust

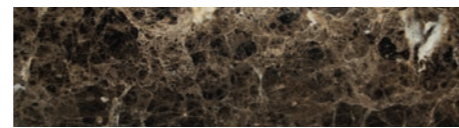

emperador dark



nero marquina



calacatta oro

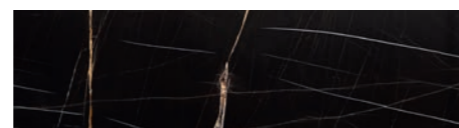

sahara noir

ESSENZE - VENEERS



rovere light



rovere cenere

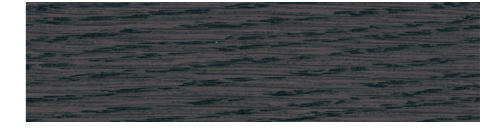

rovere grigio



rovere tabacco



rovere honey



rovere coal



termocotto

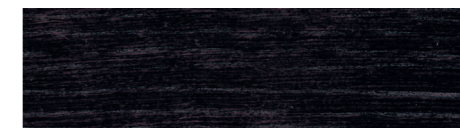

rovere wengè

MELAMINICI - MELAMINES

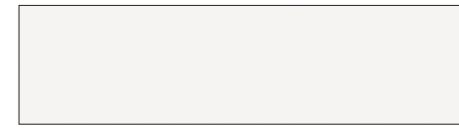

bianco



larix



shendra

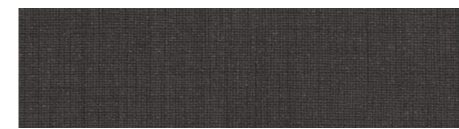

greytex



whitex

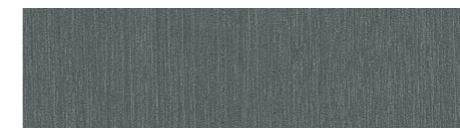

silververtex

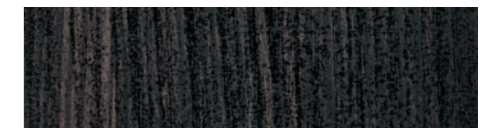

absolut



way



zenit



juglans

I campioni di colori e materiali hanno valore indicativo. The colour and material samples have an indicative value.

Technical data.

Giellesse update

**Discover the technical and  
functional qualities of the  
Giellesse products.**

**FLEXUS SISTEMA LIBRERIA . FLEXUS BOOKCASE SYSTEM**

Flexus sistema libreria a spalle portanti e ripiani disponibile in 9 altezze, 5 larghezze e 3 profondità. L'ampia modularità consente al sistema di adattarsi ad ogni soluzione architettonica. Le spalle e i ripiani hanno spessore 30 mm. Ante in legno o vetro, apertura battente, scorrevole o a ribalta; cassetti in legno. Flexus bookcase system available in 9 different heights, 5 widths and 3 depths. The wide modularity gives the possibility to adapt the system to any possible architectural solution. Vertical side panels and shelves are 30 mm thickness. Wooden or glass doors, hinged, sliding and flap down opening; wooden drawers.

**dimensioni . dimensions**

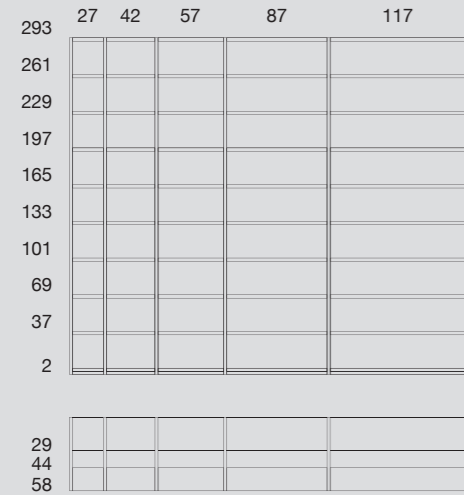

**larghezza totale . total width**

Per ottenere la larghezza totale della composizione aggiungere 30 mm del fianco finale. To get the total width of the composition add 30 mm of the final vertical side panel.

**FRAME SISTEMA CONTENITORI . FRAME STORAGE UNITS SYSTEM**

Frame sistema contenitori è un programma componibile basato sul libero accostamento di un'ampia varietà di elementi a terra e a parete. Consente di comporre liberamente composizioni anche di dimensioni ridotte. Frame storage units system is a composable program that allows the combination of a wide range of elements both suspended and wall standing. Freely usable, the system allows the creation of compositions even with reasonable dimensions.

**componenti . components**

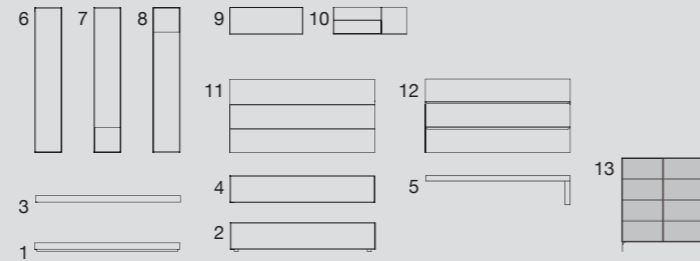

- 1 panca a terra . floor bench
- 2 elemento a terra . floor element
- 3 panca sospesa . suspended bench
- 4 elemento sospeso orizzontale . suspended horizontal element
- 5 panca in sovrapposizione a elemento a terra . bench in superposition to floor element
- 6 elemento sospeso verticale . suspended vertical element
- 7 elemento sospeso verticale con vano a giorno inferiore . suspended vertical element with lower open unit
- 8 elemento sospeso verticale con vano a giorno superiore . suspended horizontal element with upper open unit
- 9 elemento sospeso in metallo . suspended metal element
- 10 elemento raster . raster
- 11 boiserie con mensole in metallo . wooden panel with metal shelves
- 12 boiserie con mensole in legno . wooden panel with wooden shelves
- 13 elemento su piedi . element on feet

**CABIN SISTEMA CABINA . CABIN WALK-IN CLOSET**

Cabin sistema cabina armadio con pannelli a parete, attrezzabile con un'ampia gamma di accessori come ripiani, tubi appendiabito, porta pantaloni, portaoggetti, cassettiere sospese, a terra e su ruote. Cabin is a walk-in closet system with vertical wall panels, the system can be equipped with a wide range of accessories such as shelves, clothes bars, trousers rack, storage trays, chest of drawers suspended, floor standing or on wheels

**altezza modulo . unit height**



**larghezza modulo . unit width**



**profondità modulo . unit depth**



**SESTANTE SISTEMA ANTE . SESTANTE SYSTEM DOORS**

Sestante è un sistema di ante scorrevoli per chiudere le cabine armadio o separare ambienti senza togliere continuità agli spazi. Le ante sono in finitura alluminio anodizzato o verniciato in tutti i colori a campionario e sono personalizzabili con tutte le tipologie di cristallo offerte. Sestante is a system of sliding doors to close walk-in closets or to divide areas maintaining continuity of space. Doors are available in aluminum or lacquered in any color of the samples collection. Customizable with any glass from the collection.

**larghezza ante . doors widths**

Larghezze disponibili da 700 a 1700\* mm  
Altezze disponibili da 2250 a 3000 mm  
\* L. 700/1500 - H. max 3000  
L. 1500/1700 - H. max 2250

Widths from 700 to 1700\* mm  
Heights from 2250 to 3000 mm  
\* W. 700/1500 - H. max 3000  
W. 1500/1700 - H. max 2250

**scorrevole a parete . sliding with wall beam**

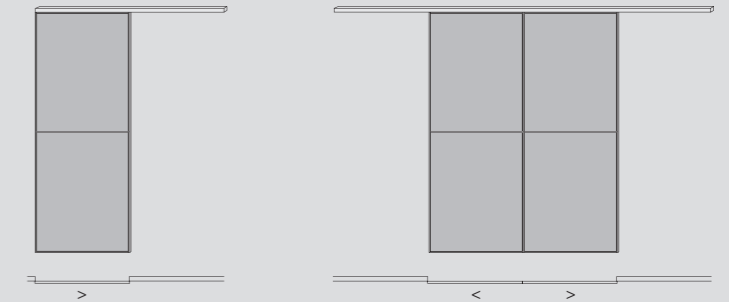

**scorrevole a soffitto . sliding with ceiling beam**

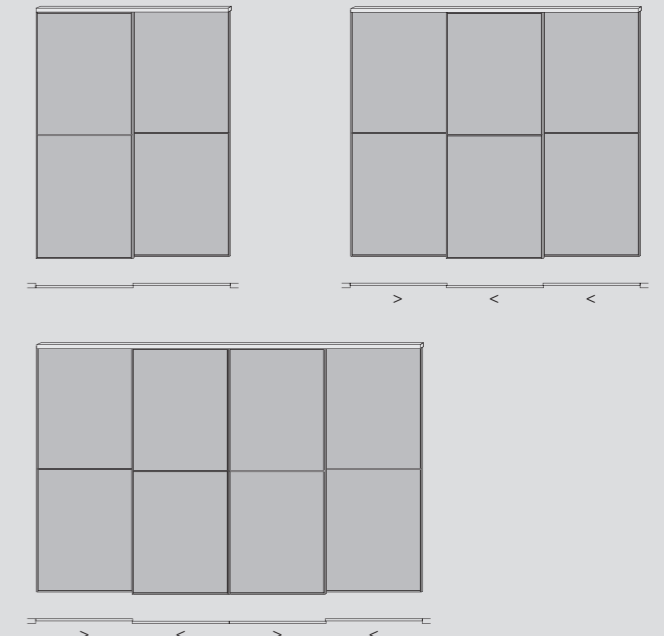

## OTTOPIÙ SISTEMA ARMADI . OTTOPIÙ WARDROBE

Ottopiù sistema armadi e cabina armadio senza ante progettati con una vastissima gamma di modularità, per sfruttare al meglio ogni spazio della zona notte. Ottopiù wardrobe and walk-in wardrobe system without doors, designed with a wide range of modularity to make the most of each space in the night area.

### componenti struttura . structure components

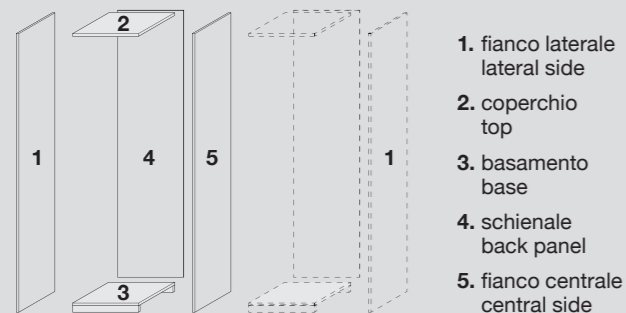

### Finiture / finishes

Finiture pannello: melaminico (tutte le finiture a campionario), laccato opaco, laccato lucido, rovere poro aperto, rovere tinto, rovere termocotto, specchio, specchio fumè, vetro laccato lucido, vetro laccato opaco. Finiture profilo maniglia: laccato colore opaco. Finishes of panel: melamine (all finishes in the collection), matt lacquered, glossy lacquered, lacquered open pore oak, veneer oak, thermo treated oak, mirror, smoked mirror, glossy lacquered glass, matt lacquered glass. Finishes of frame: matt lacquered.

### battente . hinged

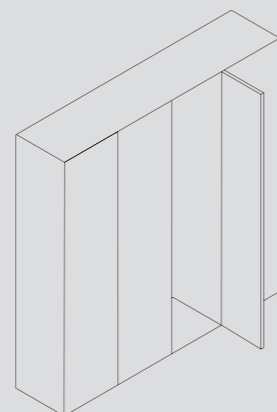

Tutte le ante battenti sono fornite con cerniere ammortizzate. All leaf doors are supplied with soft closing hinges.

### dimensioni . dimensions

H. 285 / 294,8 solo per modelli Arizona, Glide, Groove, Outdoor (Low / High). Per il calcolo dell'altezza utile interna togliere sempre 11 cm dall'altezza totale della composizione). H. 285 / 294,8 only for models Arizona, Glide, Groove, Outdoor (Low / High). To get the real available inner height always remove 11 cm from the total height.

Profondità struttura 58 cm – Profondità interna 56,3 cm. Profondità totale (spalla + anta) 61 cm. Depth of structure 58 cm – Inner available depth 56,3 cm. Overall depth (vertical side + door) 61 cm.

Per ottenere la larghezza totale della composizione aggiungere sempre 2,5 cm del fianco laterale. To get the total width of the composition always add 2,5 cm of the external side panel.

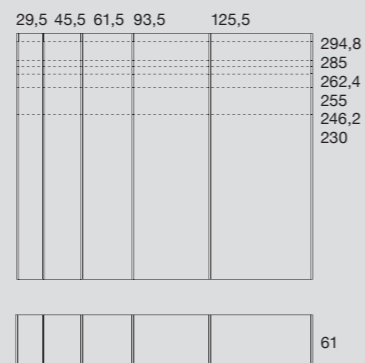

### modularità . modularity

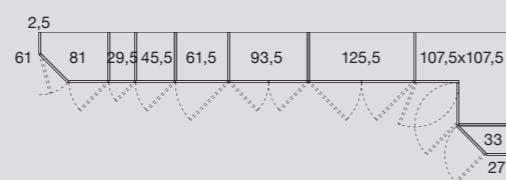

### libro . folding

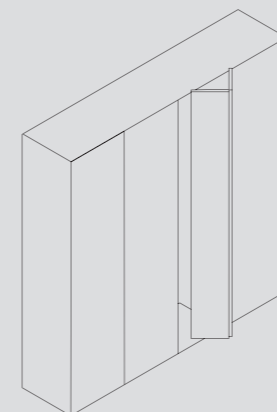

### dimensioni . dimensions

H. 285 / 294,8 solo per modello Arizona. Per il calcolo dell'altezza utile interna togliere sempre 11 cm dall'altezza totale della composizione). H. 285 / 294,8 only for model Arizona. To get the real available inner height always remove 11 cm from the total height.

Profondità struttura 58 cm – Profondità interna 56,3 cm. Profondità totale (spalla + anta) 61 cm. Depth of structure 58 cm – Inner available depth 56,3 cm. Overall depth (vertical side + door) 61 cm.

Per ottenere la larghezza totale della composizione aggiungere sempre 2,5 cm del fianco laterale. To get the total width of the composition always add 2,5 cm of the external side panel

Per ottenere la larghezza totale della composizione aggiungere sempre 2,5 cm del fianco laterale. To get the total width of the composition always add 2,5 cm of the external side panel

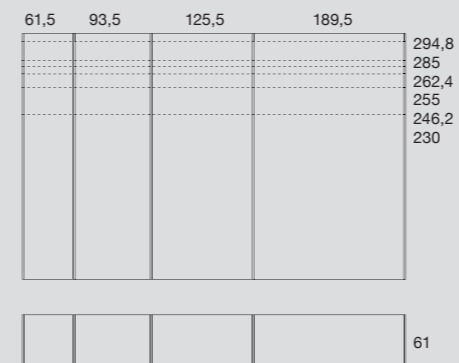

### modularità . modularity

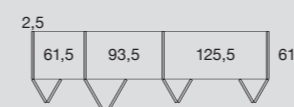

### scorrevole, scorrevole complanare . sliding, sliding coplanar

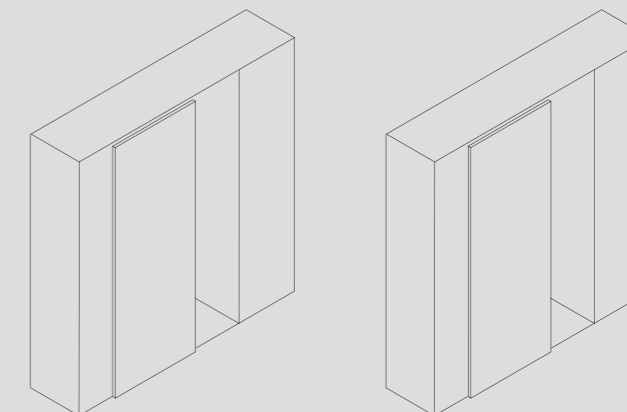

### dimensioni . dimensions

H. 285 / 294,8 solo per modelli Arizona (con maniglioni). Per il calcolo dell'altezza utile interna togliere sempre 17 cm dall'altezza totale della composizione). H. 285 / 294,8 only for model Arizona (with vertical big handles). To get the real available inner height always remove 17 cm from the total height.

Profondità struttura 58 cm – Profondità interna 56,3 cm. Profondità totale (spalla + anta) da 61 a 66 cm. Depth of structure 58 cm – Inner available depth 56,3 cm. Overall depth (vertical side + door) from 61 to 66 cm.

Per ottenere la larghezza totale della composizione aggiungere sempre 2,5 cm del fianco laterale. To get the total width of the composition always add 2,5 cm of the external side panel.

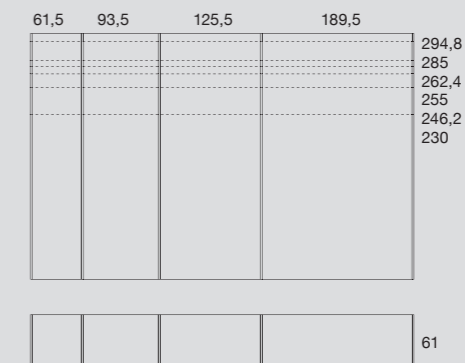

### modularità . modularity

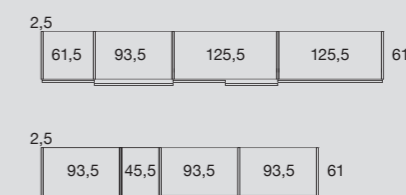





P 6.7

Composizione Frame: base a terra rovere termocotto con top marmo Calacatta oro, panca sospesa e boiserie rovere termocotto, pensili laterali laccato lucido grigio ice con ante in vetro profilo laccato metal champagne e vetro bronzo. Divano Downtown rivestito in tessuto, basamento a terra metal champagne. Tavolino quadrato Tudor, struttura rovere termocotto, top marmo Calacatta oro. Tavolino tondo Jerry struttura laccato metal champagne, top rovere termocotto. Madia Frame laccato opaco cioccolato. Frame composition: floor element in thermo-treated oak with Calacatta gold marble top, suspended bench with thermo-treated oak back panels, glossy lacquered grigio ice suspended vertical element with champagne frame and bronzed glass doors. Downtown sofa with metal champagne base and fabric covering. Squared table Tudor, with thermo-treated oak structure and Calacatta marble top. Jerry coffee table with metal champagne lacquered base and thermo-treated oak top. Matt lacquered cioccolato Frame sideboard.



## TUDOR

Tavolino con struttura in legno e top in marmo. Finiture struttura: rovere tinto e rovere termocotto. Finiture top: marmo. Coffee table with wooden structure and marble top. Structure finish: veneer oak and thermo-treated oak. Top finish: marble.

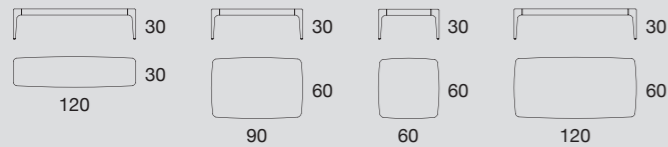

## JERRY

Tavolini con struttura in metallo e piano in legno. Finiture: laccato opaco, laccato lucido, rovere tinto, rovere termocotto. Coffee table with metal structure and wooden top. Finishes: matt lacquered, glossy lacquered, oak veneer, thermo treated oak.

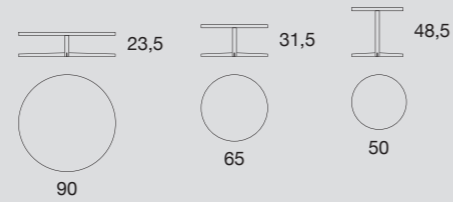

## DOWNTOWN

Divano componibile con struttura in legno, imbottitura in poliuretano espanso a densità differenziata. Rivestimento in tessuto sfoderabile o pelle. Basamento a terra in tubolare di metallo. Modular sofa with wooden structure, polyurethane padding with different density. Removable cover in fabric or leather. Metal lacquered base.

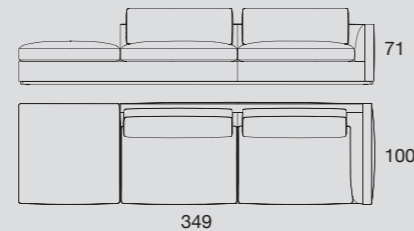

## FRAME

Frame sistema contenitori è un programma componibile basato sul libero accostamento di un'ampia varietà di elementi a terra e a parete. Consente di comporre liberamente composizioni anche di dimensioni ridotte. Frame storage units system is a composable program that allows the combination of a wide range of elements both suspended and wall standing. Freely usable, the system allows the creation of compositions even with reasonable dimensions.

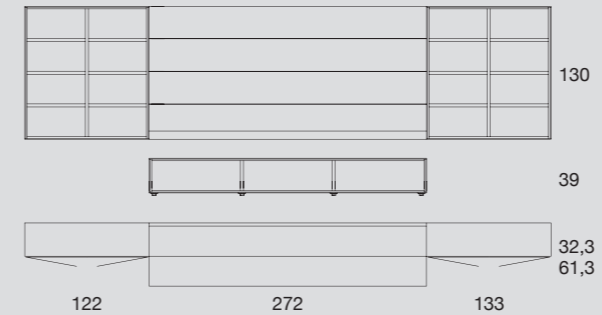

## FRAME MADIA

Frame sistema contenitori è un programma componibile basato sul libero accostamento di un'ampia varietà di elementi a terra e a parete. Consente di comporre liberamente composizioni anche di dimensioni ridotte. Frame storage units system is a composable program that allows the combination of a wide range of elements both suspended and wall standing. Freely usable, the system allows the creation of compositions even with reasonable dimensions.

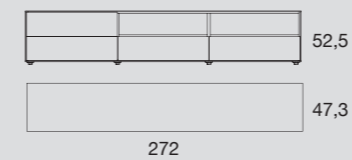

P 16.17

Composizione Flexus Cristal: struttura metal rame, vetro trasparente, cassetti rovere coal. Cristal Flexus composition: metal rame structure, transparent glass, coal oak drawers.

## FLEXUS

Flexus sistema libreria a spalle portanti e ripiani disponibile in 9 altezze, 5 larghezze e 3 profondità. L'ampia modularità consente al sistema di adattarsi ad ogni soluzione architettonica. Le spalle e i ripiani hanno spessore 30 mm. Ante in legno o vetro, apertura battente, scorrevole o a ribalta; cassetti in legno. Flexus bookcase system available in 9 different heights, 5 widths and 3 depths. The wide modularity gives the possibility to adapt the system to any possible architectural solution. Vertical side panels and shelves are 30 mm thickness. Wooden or glass doors, hinged, sliding and flap down opening; wooden drawers.

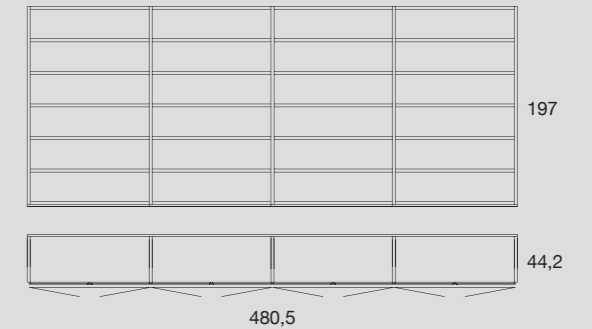

P 18.19

Madia Select laccato lucido grigio ice, vassoio e supporti laterali laccati metal bronzo. Select sideboard in glossy lacquered grigio ice, with metal bronzo lacquered upper tray and sides.

## SELECT

Select sistema madie con struttura in legno, vassoio e supporti laterali laccati. Finiture struttura: laccato opaco, laccato lucido, rovere tinto e rovere termocotto. Finiture supporti laterali e top: laccato metal. Select sideboard system with wooden structure, metal lacquered tray and sides. Structure finishes: matt lacquered, glossy lacquered, veneer oak and thermo-treated oak. Sides and top finishes: metal lacquered.

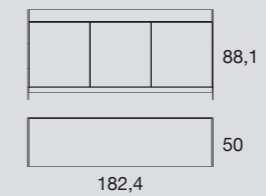



P 22.23

Composizione Frame: base rovere honey e laccato opaco antracite, boiserie rovere honey e laccato opaco antracite, pensili laccato opaco antracite con telaio metal vulcano e vetro fumè. Frame composition: honey oak and matt lacquered antracite base, honey oak and matt lacquered antracite back panels, matt lacquered antracite suspended vertical element with metal vulcano frame and smoked glass.

## FRAME

Frame sistema contenitori è un programma componibile basato sul libero accostamento di un'ampia varietà di elementi a terra e a parete. Consente di comporre liberamente composizioni anche di dimensioni ridotte. Frame storage units system is a composable program that allows the combination of a wide range of elements both suspended and wall standing. Freely usable, the system allows the creation of compositions even with reasonable dimensions.

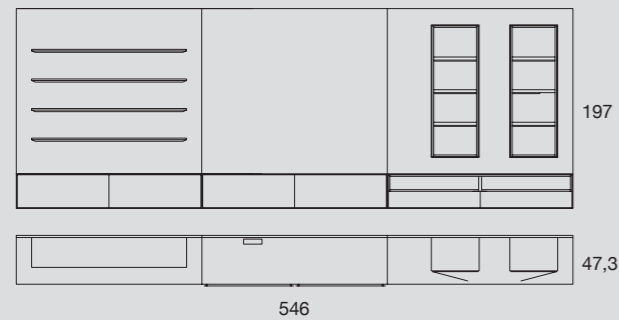

P 24.25

Composizione Flexus: laccato opaco grigio cloud, schienali ceramica Ceppo di Gré. Divano Downtown rivestito in tessuto, basamento a terra metal champagne. Tavolino quadrato Tudor struttura rovere termocotto, top marmo calacatta oro. Tavolino tondo Jerry struttura laccato metal champagne, top rovere termocotto. Specchiera Jam cornice laccato metal champagne e specchio bronzo. Flexus composition: matt lacquered grigio cloud, back panels in Ceppo di Gré ceramic. Downtown sofa in fabric covering, metal champagne base. Squared table Tudor, with thermo-treated oak structure and

Calacatta marble top. Jerry coffee table with metal champagne lacquered base and thermo-treated oak top. Jam mirror, with metal champagne lacquered frame and bronzed mirror.

## FLEXUS

Flexus sistema libreria a spalle portanti e ripiani disponibile in 9 altezze, 5 larghezze e 3 profondità. L'ampia modularità consente al sistema di adattarsi ad ogni soluzione architettonica. Le spalle e i ripiani hanno spessore 30 mm. Ante in legno o vetro, apertura battente, scorrevole o a ribalta; cassetti in legno. Flexus bookcase system available in 9 different heights, 5 widths and 3 depths. The wide modularity gives the possibility to adapt the system to any possible architectural solution. Vertical side panels and shelves are 30 mm thickness. Wooden or glass doors, hinged, sliding and flap down opening; wooden drawers.

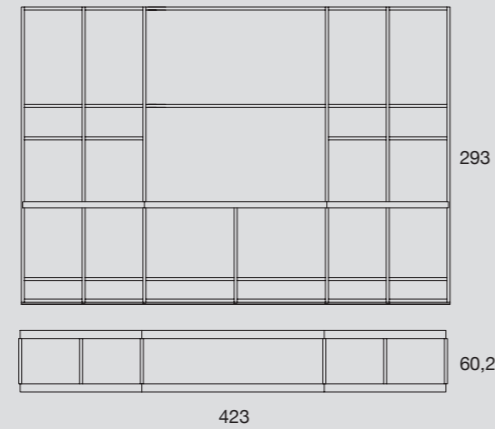

## JAM

Specchiera Jam con telaio laccato metal champagne. Finiture telaio: laccato opaco, laccato metal. Finiture specchio: bronzo e fumè. Jam mirror with metal champagne lacquered frame. Frame finish: matt lacquered, metal lacquered. Mirror finish: bronzed and smoked mirror.



P 28.29

Composizione Frame bifacciale con fianchi laterali e boiserie in rovere honey, pensili laccato opaco astro. Tavolo Pantheon struttura rovere

honey, top marmo Calacatta gold e anello base laccato metal champagne. Sedie Susan rovere honey e scocca rivestita in velluto. Sedie Clarice rovere honey e scocca rivestita in pelle. Divano Downtown rivestito in tessuto, basamento a terra metal champagne. Frame double sided composition with wooden back panels and sides in honey oak and matt lacquered astro vertical suspended element. Pantheon table with honey oak base, Calacatta marble gold and metal champagne ring base. Susan chairs with honey oak base and velvet seat. Clarice chairs with honey oak base and leather seat. Downtown sofa in fabric covering, metal champagne lacquered base.

## FRAME

Frame sistema contenitori è un programma componibile basato sul libero accostamento di un'ampia varietà di elementi a terra e a parete. Consente di comporre liberamente composizioni anche di dimensioni ridotte. Frame storage units system is a composable program that allows the combination of a wide range of elements both suspended and wall standing. Freely usable, the system allows the creation of compositions even with reasonable dimensions.

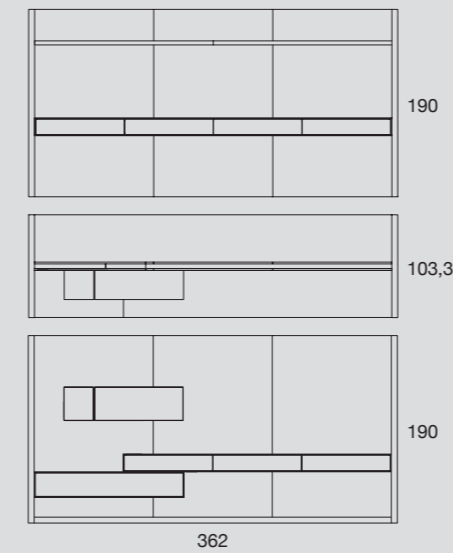

## PANTHEON

Tavolo con struttura in legno, piano e inserto girevole in legno o marmo. Finitura base: laccato metal, rovere, termocotto. Finitura piano: rovere, termocotto, marmo. Finitura anello base: laccato metal. Table with wooden structure, wooden or marble top and rotating element. Base finishes: metal lacquered, oak veneer, thermo-treated oak. Top finishes: oak veneer, thermo-treated oak, marble. Ring base finish: metal lacquered.

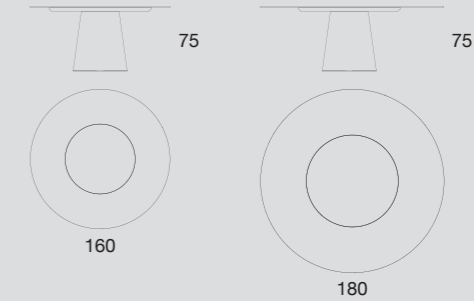

## SUSAN

Sedia con struttura in legno, seduta e schienale imbottiti e rivestiti in tessuto, pelle o ecopelle. Finiture struttura: rovere, termocotto. Chair with wooden structure, upholstered and covered seat in fabric, leather or eco leather. Structure finishes: veneer oak, thermo-treated oak.



P 33

Madia Select high rovere termocotto, vassoio e supporti laterali laccato metal champagne. Tavolo Pantheon struttura rovere honey, top marmo Calacatta gold e anello base laccato metal champagne. Sedie Susan rovere honey e scocca rivestita in velluto. Select high sideboard in thermo-treated oak, with metal champagne lacquered upper tray and sides. Pantheon table with honey oak base, Calacatta marble gold and metal champagne ring base. Susan chairs with honey oak base and velvet seat.

## SELECT

Select sistema madie con struttura in legno, vassoio e supporti laterali laccati. Finiture struttura: laccato opaco, laccato lucido, rovere tinto e rovere termocotto. Finiture supporti laterali e top: laccato metal. Select sideboard system with wooden structure, metal lacquered tray and sides. Structure finishes: matt lacquered, glossy lacquered, veneer oak and thermo-treated oak. Sides and top finish: metal lacquered.

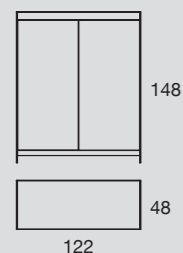

P 34.35

Madia Select laccato opaco roccia, vassoio e supporti laterali metal vulcano. Matt lacquered roccia Select sideboard with metal vulcano lacquered upper tray and sides.

## SELECT

Select sistema madie con struttura in legno, vassoio e supporti laterali laccati. Finiture struttura: laccato opaco, laccato lucido, rovere tinto e rovere termocotto. Finiture supporti laterali e top: laccato metal. Select sideboard system with wooden structure, metal lacquered tray and sides. Structure finishes: matt lacquered, glossy lacquered, veneer oak and thermo-treated oak. Sides and top finish: metal lacquered.

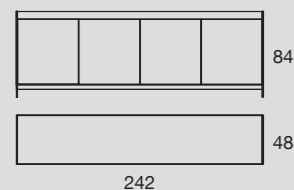

P 16.17

Composizione Flexus Crystal: struttura, e telaio ante e ripiani vetro in metal rame con illuminazione integrata, cassetti rovere coal. Flexus Crystal composition: structure, glass doors and shelves frame in lacquered metal rame with led lights, drawers in coal oak.

## FLEXUS CRYSTAL

Flexus Crystal sistema libreria a spalle portanti in alluminio. L'ampia modularità consente al sistema di adattarsi ad ogni soluzione architettonica. Ante in vetro con apertura battente; cassetti in legno. Flexus Crystal bookcase system with aluminium vertical sides. The wide modularity gives the possibility to adapt the system to any possible architectural solution. Glass doors, with hinged opening; wooden drawers.

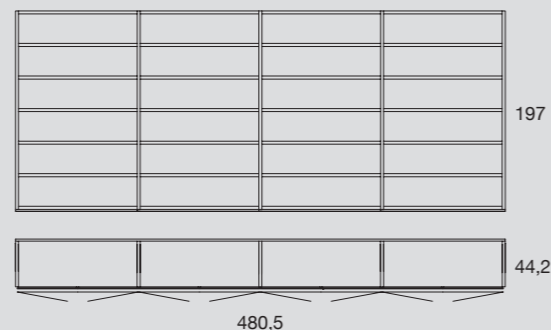

P 38.39

Letto Downtown rivestito in tessuto e tubolare a terra in finitura metal champagne. Poltroncina Club rivestita in velluto. Cassettiera Frame laccato opaco grigio cloud. Downtown bed upholstered with fabric, ground tublar in metal champagne finish. Club armchair in velvet covering. Frame chest of drawers in matt lacquered grigio cloud.

## DOWNTOWN

Letto Downtown imbottito con rivestimento in tessuto e tubolare in metal champagne. Finiture disponibili: tessuto, pelle, ecopelle. Finiture tubolare: laccato metal, laccato opaco Levante upholstered bed with fabric covering. Covering finishes: Fabric, leather, eco leather. Groun tublar finishes: lacquered metal, lacquered matt colour.

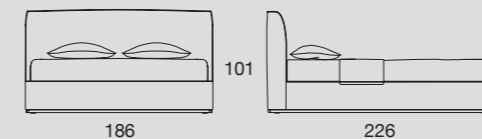

## CLUB

Poltroncina con struttura in legno, imbottita e rivestita in tessuto, pelle o ecopelle. Armchair with wooden and polyurethane structure upholstered and covered in fabric, leather or eco leather.

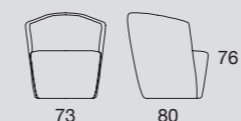

## FRAME MADIA

Frame sistema contenitori è un programma componibile basato sul libero accostamento di un'ampia varietà di elementi a terra e a parete. Consente di comporre liberamente composizioni anche di dimensioni ridotte. Frame storage units system is a composable program that allows the combination of a wide range of elements both suspended and wall standing. Freely usable, the system allows the creation of compositions even with reasonable dimensions.



P 41

Comodino Opera con struttura in rovere honey, top marmo Calacatta Gold. Letto Downtown rivestiro in tessuto e tubolare a terra in finitura metal champagne. Opera bedside table with honey oak structure and Calacatta gold marble top. Downtown bed upholstered with fabric, ground tublar in metal champagne finish.



## OPERA

Comodini, comò e settimanale con struttura in legno e top in marmo. Finiture struttura: rovere, rovere poro aperto e termocotto. Finiture top: marmo, rovere. Bedside table, chest of drawers and tallboy with wooden structure and marble top. Structure finishes: oak veneer, open pore oak and thermo-treated. Top finishes: marble, oak.

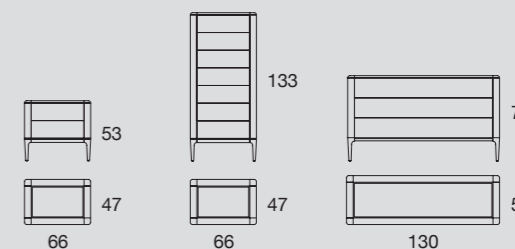

P 45

Armadio battente Cover: ante rivestite in cuoio cenere, profili con maniglie integrate metal champagne. Letto Levante con struttura e pannello testata in rovere honey, cuscini imbottiti e rivestiti in velluto Cover wardrobe: hinged cenere leather doors, metal champagne profiles with integrated handles. Levante bed with structure and headboard in honey oak and velvet cushions.



**COVER**

Armadio con apertura battente. Finiture anta: cuoio. Finitura profilo: laccato metal, laccato opaco. Wardrobe with hinged doors. Doors finishes: leather. Frame finishes: metal lacquered, matt lacquered.

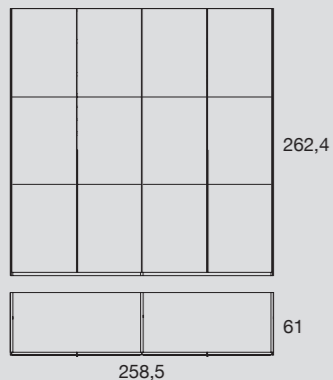

P 47

Armadio battente Portrait: ante laccato lucido grigio cloud, maniglie integrate metal champagne, interno melaminico zenit. Armadio battente Mayfair: struttura ante metal champagne e vetro structure bronzo, interno melaminico zenit. Portrait wardrobe: hinged glossy lacquered grigio cloud, metal champagne integrated handles, zenit melamine internal structure. Wardrobe Mayfair: hinged doors, with metal champagne frame and structure bronzed glass, zenit melamine internal structure.



**PORTRAIT**

Armadio con apertura battente. Finiture anta: laccato opaco, laccato lucido. Finitura maniglia integrata: laccato metal. Wardrobe with hinged doors. Door finishes: matt lacquered, glossy lacquered. Integrated handle finish: metal lacquered.

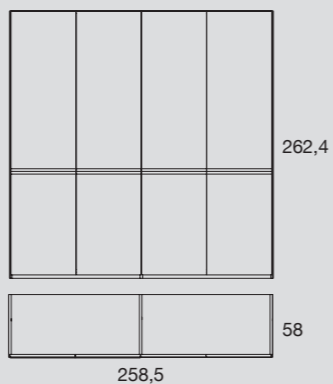

**MYFAIR**

Armadio con apertura battente. Finiture pannello: vetro. Finitura profilo: laccato opaco, laccato metal. Wardrobe with hinged doors. Panel finishes: glass. Frame finishes: matt lacquered, metal lacquered.

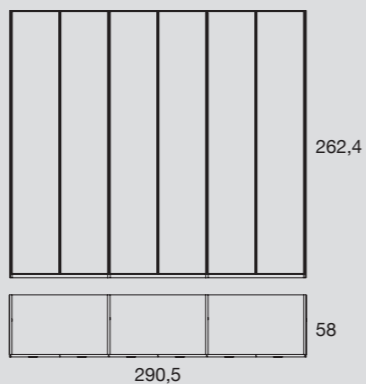

P 50.51

Armadio battente Kita: struttura ante metal champagne e vetro trasparente, interno melaminico silvertex. Portale Horizon rovere honey e laccato lucido grigio cloud, schienale luminoso. Letto Levante con struttura e pannello testata in rovere honey, cuscini imbottiti e rivestiti in velluto. Comodino Opera con struttura in rovere honey, top marmo Calacatta Gold. Cassetiera Frame laccato opaco cioccolato. Sedia Susan rovere honey e scocca rivestita in velluto. Wardrobe Kita: hinged doors with metal champagne frame and transparent glass, internal structure in silvertex melamine. Horizon portal in honey oak and glossy lacquered grigio cloud, full LED lights back panel. Levante bed with structure and headboard in honey oak and velvet cushions. Opera bedside table with honey oak structure and Calacatta gold marble top. Frame chest of drawers in matt lacquered cioccolato. Susan chairs with honey oak base and velvet seat.



**KITA**

Armadio con apertura battente. Finiture struttura anta: laccato metal. Finitura pannello: vetro. Wardrobe with hinged doors. Door structure finishes: metal lacquered. Panel finishes: glass.

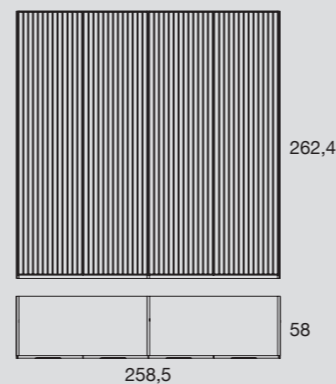

**HORIZON**

Portale. Finiture: laccato opaco, laccato lucido, rovere, rovere termocotto. Portal. Finishes: matt lacquered, glossy lacquered, oak veneer, thermo-treated oak.

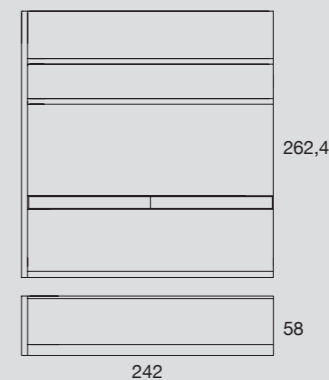

P 36.37

**PIVOT**

Armadio Pivot: struttura ante metal vulcano e vetro fumè, cassetti interni laccato opaco rosso falun. Pivot wardrobe: doors' structure metal vulcano and smoke grey glass, inner drawers matt lacquered rosso falun.

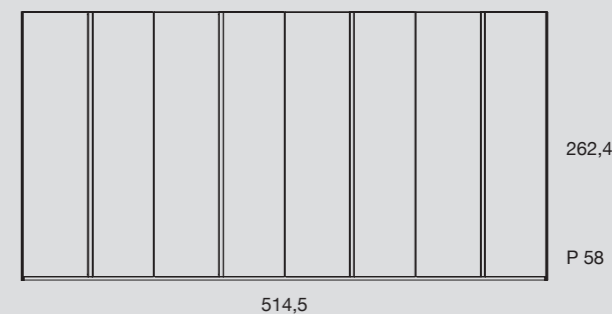



P 53

Armadio battente Groove Plus: ante rovere termocotto, profilo con maniglia integrata metal gold. Letto Levante con struttura e pannello testata in rovere honey, cuscini imbottiti e rivestiti in velluto. Groove Plus wardrobe: hinged doors in thermo-treated oak, metal gold frame and integrated handle. Levante bed with structure and headboard in honey oak and velvet cushions.



### GROOVE PLUS

Armadio con apertura battente. Finiture anta: laccato opaco, laccato lucido, rovere, rovere termocotto. Finitura profilo con maniglia integrata: laccato metal. Wardrobe with hinged doors. Door finishes: matt lacquered, glossy lacquered, oak veneer, thermo-treated oak. Frame and integrated handle finish: metal lacquered.

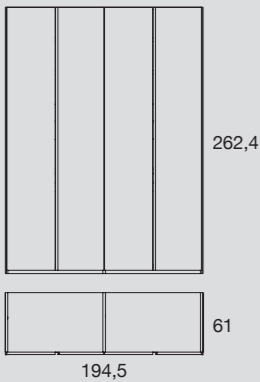

P 55

Cassettiera Long Island rovere termocotto, top rivestito in cuoio tortora. Pouf Soft Square imbottito e rivestito in velluto. Long Island chest of drawing in thermo-treated oak, tortora leather top. Soft Square Pouffe upholstered and covered in velvet.



### LONG ISLAND

Isola con 8 cassetti e 9 vani a giorno. Finiture: laccato opaco, laccato lucido, rovere, rovere termocotto. Finiture top: cuoio. Island with 8 drawers and 9 open units. Finishes: matt lacquered, glossy lacquered, oak veneer, thermo-treated oak. Top finishes: leather.

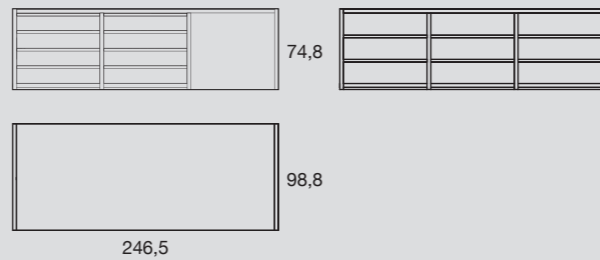

### SOFT SQUARE, CIRCLE, TRIANGLE

Pouf con struttura in legno, imbottito e rivestito in tessuto o pelle. Pouffe with wooden structure covered in fabric or leather.

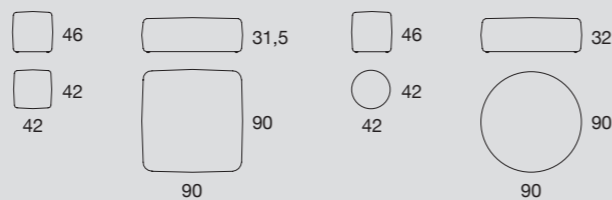

P 59

Armadio scorrevole complanare Sheer: ante vetro stopsol fumè e profilo metal vulcano, interno melaminico silvertex con cassettiere laccato opaco grigio cloud. Coplanar wardrobe Sheer: stopsol smoked glass doors with metal vulcano lacquered frame, internal structure in silvertex melamine with matt lacquered grigio cloud drawers.



### SHEER

Armadio con apertura scorrevole complanare. Finiture anta: vetro. Finiture profilo: laccato metal. Sliding coplanar wardrobe. Door finishes: glass. Frame finishes: metal lacquered.

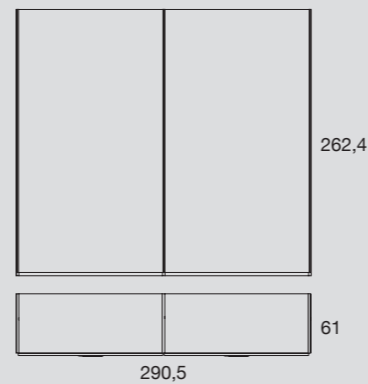

P 60.61

Cabina armadio Cabin: schienali melaminico realtex, attrezzatura rovere termocotto, tubi metal vulcano. Ante scorrevoli Genius telaio metal vulcano e vetro stopsol fumè. Walk-in closet Cabin: realtex melamine back panels, thermo-treated oak elements and metal vulcano bar clothes. Sliding doors Genius with metal vulcano frame and stopsol smoked glass.

### CABIN

Cabin sistema cabina armadio con pannelli a parete, attrezzabile con un'ampia gamma di accessori come ripiani, tubi appendiabito, porta pantaloni, portaoggetti, cassettiere sospese, a terra e su ruote. Cabin is a walk-in closet system with vertical wall panels, the system can be equipped with a wide range of accessories such as shelves, clothes bars, trousers rack, storage trays, chest of drawers suspended, floor standing or on wheels.

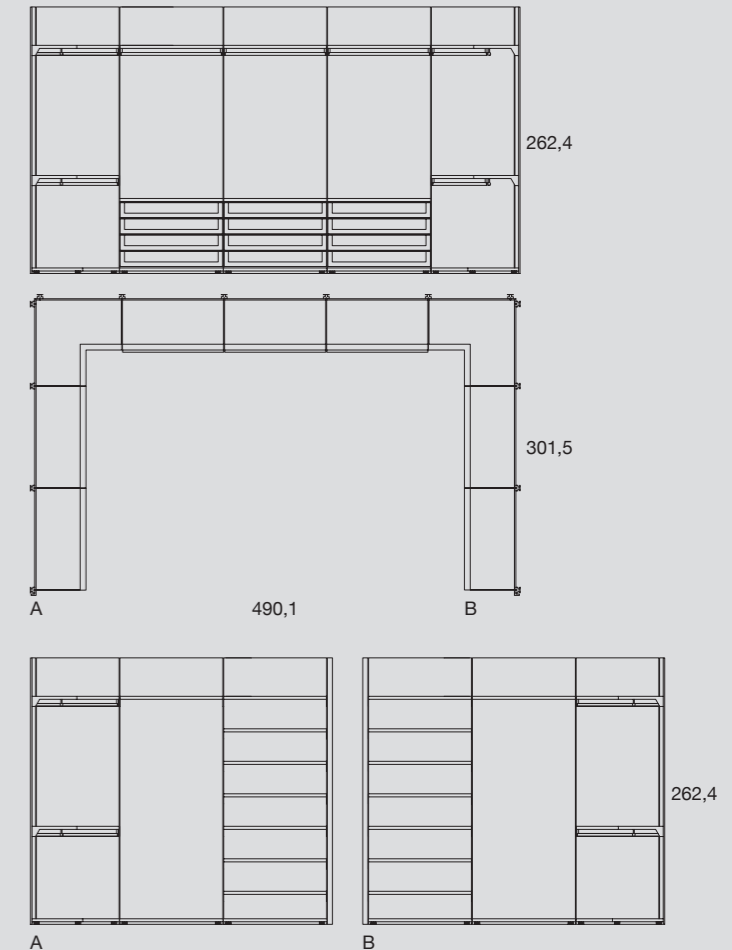

Art direction: Lorenzo De Grandis  
Styling: Cristina Corbetta  
Photos: Lorenzo Pennati  
Photoengraving: Alt@aLuce  
Printing: Grafiche Boffi  
© Giellesse, 2022

Giellesse  
via Prealpi, 34  
22044 Inverigo (Co), Italy  
T +39 031 607090  
F +39 031 606541  
giellesse@giellesse.it  
www.giellesse.it

